

中华人民共和国航空工业标准

光杆公差带 f9 100° 沉头螺栓

HB 7200-95

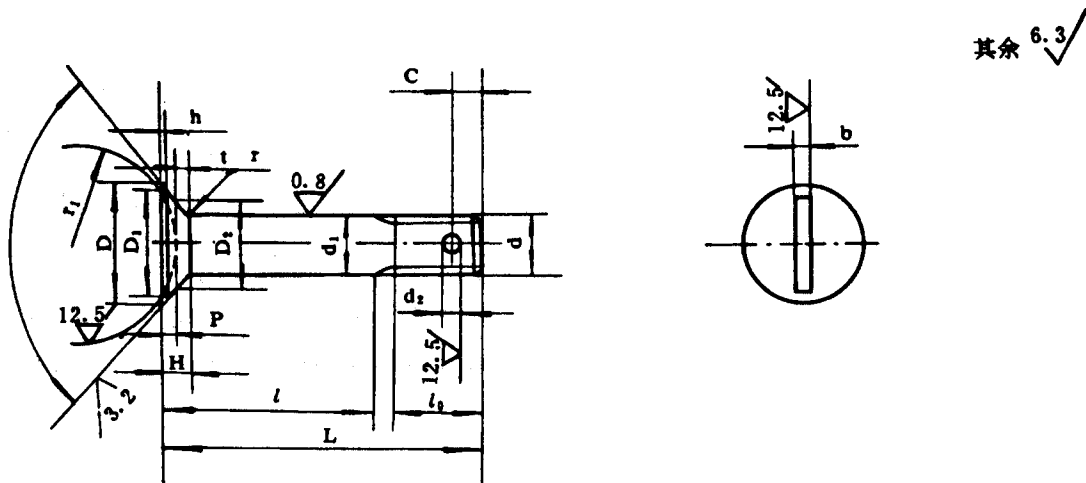

标记示例: $d_1 = 6\text{mm}$, $L = 36\text{mm}$ 的螺栓,

无开口销孔 HB 7200-6×36

有开口销孔($C = 3\text{mm}$) HB 7200-6×36×3

表 2

mm

d_1 (f9)	5	6	8	10	12	14	16	18	20
d	M5	M6	M8	M10	M12 ×1.5	M14 ×1.5	M16 ×1.5	M18 ×1.5	M20 ×1.5
H(参考)	2.11	2.53	3.38	4.23	5.07	5.92	6.77	7.61	8.46
hmin	0.10	0.10	0.10	0.10	0.10	0.10	0.10	0.10	0.10
D(参考)	10	12	16	20	24	28	32	36	40
$D_{1\text{min}}$	9.0	10.8	14.8	18.8	22.8	26.8	30.3	34.3	38.6
$D_2^{1)}$	7.71	9.00	12.21	15.43	18.00	20.57	24.43	25.71	28.92
l_0 (参考)	8.5	10.0	11.5	15.0	17.0	19.0	21.0	23.0	25.0

续表 2

mm

$d_1(f9)$		5	6	8	10	12	14	16	18	20
P	max	0.96	1.26	1.60	1.93	2.53	3.14	3.20	4.35	4.68
	min	0.88	1.18	1.52	1.85	2.45	3.06	3.12	4.27	4.60
r	max	0.5	0.7	0.7	0.8	0.9	1.1	1.1	1.3	1.3
	min	0.3	0.5	0.5	0.6	0.6	0.8	0.8	1.0	1.0
b(H12)		1.2	1.5	1.5	2.0	2.5	2.5	2.5	3.0	3.0
t(h14)		1.2	1.5	2.0	2.5	2.5	3.0	3.0	3.0	3.0
d_2		1.6	1.6	2.0	2.5	2.5	2.5	3.2	3.2	3.2
r_1		8.0	10.0	12.5	15.0	17.5	20.0	22.5	25.0	25.0
C(参考)		3	3	4	4	4.5	4.5	5	5	5.5

注:1)供测量用。

表 3

mm

$L \backslash d_1$		5	6	8	10	12	14	16	18	20
基本尺寸	极限偏差	l								
16	±0.2	6								
18		8	6							
20		10	8							
22		12	10	8						
24	±0.3	14	12	10						
26		16	14	12						
28		18	16	14	10					
30		20	18	16	12					
32		22	20	18	14	12				
34		24	22	20	16	14				
36		26	24	22	18	16	14			
38		28	26	24	20	18	16			
40		30	28	26	22	20	18	16		
42		32	30	28	24	22	20	18		
44		34	32	30	26	24	22	20	18	
46		36	34	32	28	26	24	22	20	
48	38	36	34	30	28	26	24	22	20	
50	40	38	36	32	30	28	26	24	22	
52	±0.5		40	38	34	32	30	28	26	24
54			42	40	36	34	32	30	28	26